

West Marine

BATTERY COMBINER Installation Instructions

TWO BANK, 70 A MODEL 134074 AND THREE BANK, 70 A MODEL 134090

TWO BANK, 130 A MODEL 134108 AND 130 A UPGRADE KIT MODEL 542159

TWO BANK, 200 A MODEL 308280 AND 200 A UPGRADE KIT MODEL 308298

SUMMARY

The West Marine Battery Combiner is a voltage-sensing, battery parallel solenoid which connects batteries together under certain conditions. When your batteries are being charged (above 13.1V DC), the Battery Combiner connects either two or three batteries together so they are charged simultaneously. When the voltage drops to 12.8V DC or less, the batteries are automatically disconnected from each other. This eliminates the need to change the battery switch from one setting to another while operating the boat.

The Battery Combiner is easily installed with no modification to alternator wiring. One wire connects to each bank, and a ground wire goes to negative.

FEATURES

- Insignificant voltage drop. Allows all batteries to reach full charge.
- Minimal wasted charging power.
- No heat sink or cooling required.
- Can be used on alternators with internal regulators.
- No special wiring on alternators with external voltage sense.
- Simple installation-one wire to each battery bank and a ground.
- Alternator (optionally) can be permanently connected to a battery bank.
- LED indicator lights when operating.
- Insignificant power consumption when not charging.
- Works with **shore** power chargers, solar panels, and wind generators
- No diodes to burn out if accidentally shorted.
- Designed **for** 12 volt marine electrical systems.
- Maximum alternator size: 100 amps (70 amp models) or 200 amps (130 and 200 amp models).
- Current consumption when combining:
Model: Current:
70-2 0.2 A
70-3 0.4 A
130-2 and 200-2 0.5 A
130-3 and 200-3 1.0 A

General Theory of Operation:

The Combiner is attached to the positive terminal of each battery bank and to ground. When the voltage on any bank rises due to charging

above 13.1 volts, the Combiner closes a contactor which connects the banks together as if you had selected the BOTH setting on your battery switch. When the voltage falls to below 12.8 volts, the combiner disconnects the banks from one another. To prevent the Combiner from rapidly cycling off and on, a circuit inside allows approximately 30 seconds between each activation. The voltage difference of 0.3 volts also reduces cycling.

DIFFERENT WIRING METHODS FOR THE WEST MARINE BATTERY COMBINER

There are several wiring methods which you can use when installing your Battery Combiner. The method you decide to use generally depends on 1) how your boat is wired currently, and 2) how much rewiring you feel like doing. Read through all of this information before deciding one which method is the best for you:

Method 1 - Simple, least intrusive installation:

This works well for power or sail boats that have a single OFF-I-BOTH-2 battery switch and two similar batteries or battery banks. The Battery Combiner is wired directly to your batteries, using at least 3' of the gauge wire specified by each Battery Combiner. Since there is no way to de-energize the wires leading between the Battery Combiner and the batteries, you should install fuses or circuit breakers between the batteries and the Battery Combiner. When either battery bank is charged from any source, the other battery bank will also be charged, regardless of the position of the battery switch. While underway, you can leave your battery switch on position 1 or 2, so that both batteries will not be depleted when the engine is shut off. See Figure 1.

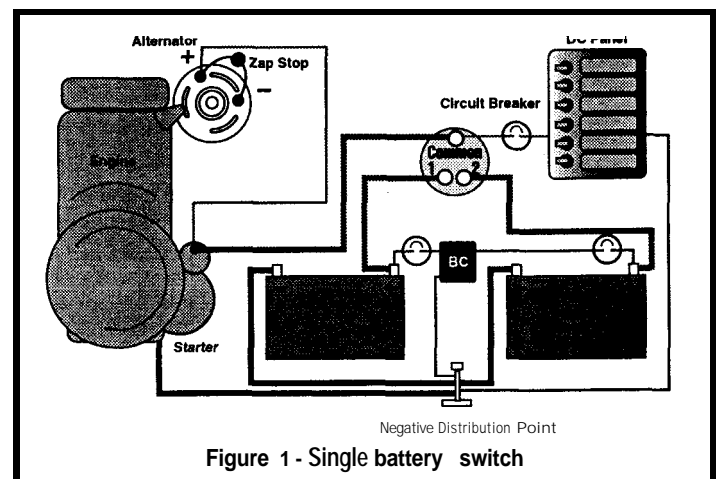

Figure 1 - Single battery switch

If you designate one battery to be the primary use battery, and the other to be the emergency starting battery, you can select a larger battery than normal for the primary battery and a smaller, purpose built battery for the emergency starting battery. Alternatively, you can alternate which battery gets used each day of operation.

Method 2-The two battery switch installation

The installation described above has the following drawbacks:

- It necessitates that the battery switch be operated frequently, which could inadvertently lead to alternator diode damage.
- It allows the operator to leave the switch in the BOTH position, thus allowing both batteries to be discharged to the point where the engine cannot be started.
- It does not isolate the electronics and other circuits on board from the low voltage resulting from starting which causes electronics to "crash".

We strongly recommend, therefore, a switching arrangement that allows house and engine loads to be separately controlled. One option is to add a second OFF-I-BOTH-2 battery switch to your electrical system. All of your house loads run through one of the battery switches, and all of the engine related loads run through the other battery switch. By wiring the switches as shown in Figure 2, you can cross-connect the engine starting loads to the house battery in an emergency. The Combiner will insure that both battery banks get charged no matter which battery is receiving the charge current.

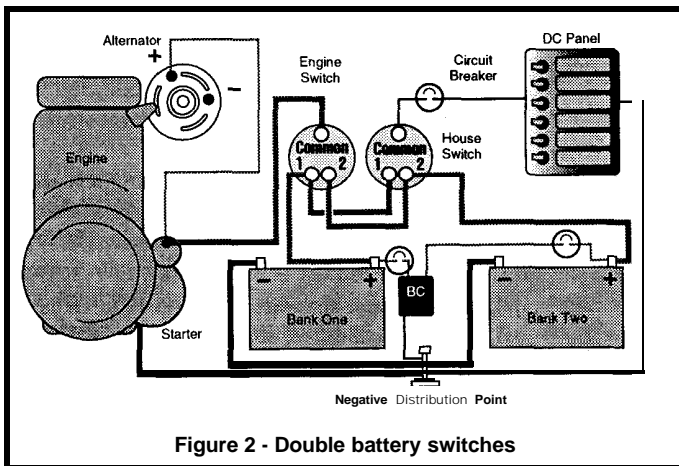

Figure 2 - Double battery switches

Method 3-The three battery switch installation:

A better alternative, in our view, is shown in Figure 3, and it uses three simple ON-OFF battery switches. While three switches may seem like overkill, the simplicity of the operation of this system is its beauty.

One switch (the House Battery Switch) installs between the house bank and the house loads. It controls whether the house battery is connected to other circuits in the boat. When this switch is OFF, the house bank is isolated. A second switch (the Engine Battery Switch) installs between the engine starting battery and the engine. When this switch is OFF, the engine battery is isolated.

A third switch (the Emergency Parallel Switch) installs between the other two switches, and allows the engine and house loads to be cross-connected in case one of the batteries fails. This switch should be mounted in an inconspicuous location since it should remain OFF 99.9% of the time, and it can allow BOTH batteries to be depleted if it is turned on by mistake.

In normal operation, the Engine and House switches are turned ON, and left there for the duration of the voyage. The Battery Combiner connects the positive terminals of the batteries.

Note that the battery switches do not control whether the Battery Combiner can parallel the batteries. If you have a failed battery, you will need to disconnect the wire which leads to it in order to defeat the Battery Combiner, or you will apply current to the dead battery.

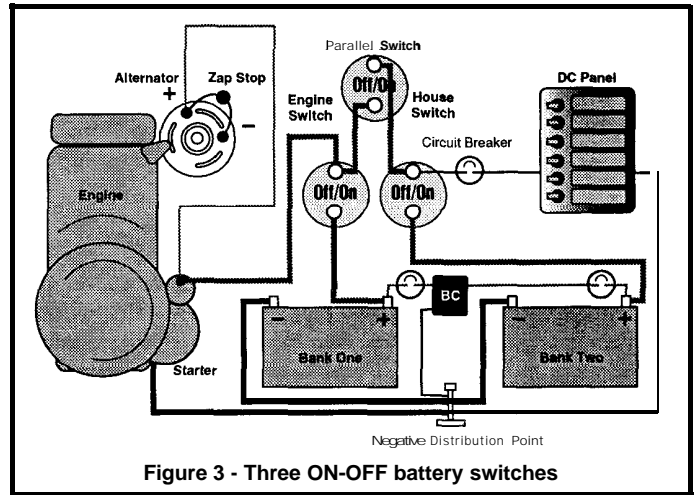

Figure 3 - Three ON-OFF battery switches

Method 4-Single engine powerboats:

Many powerboats in the 16-22 foot range come from the factory with a single battery for all electrical loads, including starting. When owners of these boats begin to add more and more electrical products, frequently for fishing, voyaging, or entertaining, it becomes important to reserve one battery for engine starting, and reserve another battery for DC loads. Once again, however, if the operator leaves the battery switch in the BOTH position for charging, there is a likelihood that both batteries will become depleted at some point.

A better idea is to use a Battery Combiner, an OFF-I-BOTH-2 switch, and a separate wire leading to the DC loads. When the boat is in operation, leave the battery switch on position 1, so that Battery 1 can start the engine, and get charged by the engine. Use Battery 2 for the DC loads, and use the Battery Combiner to make sure it gets charged when the engine is running. If Battery 1 should become discharged for any reason, use Battery 2 for starting by moving the switch. The DC load supply wire should be properly fused within 7" of Battery 2. See Figure 4.

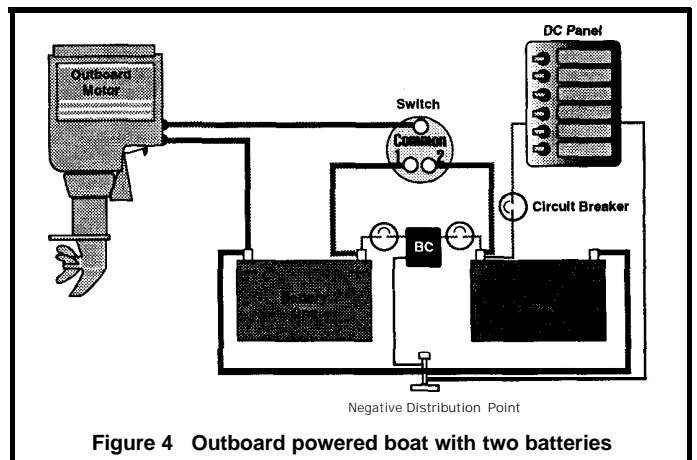

Figure 4 Outboard powered boat with two batteries

Method 5 - Twin engine powerboats:

Twin engine powerboats generally have a starting battery for each engine, and may have one or two house banks of batteries as well. There are many variations on how twin engine boats can be wired, but one of the easiest methods is to use a 3-Bank Battery Combiner which will join the two starting banks and the house bank together when the voltage rises as a result of the engines being on. See Figure 5.

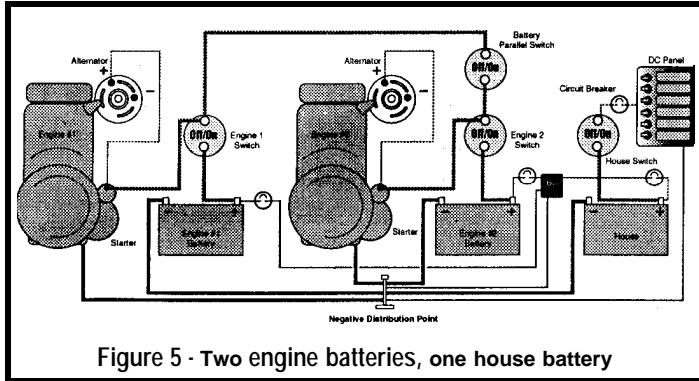

Figure 5 - Two engine batteries, one house battery

Alternatively, many boats are wired with a single engine starting battery, and a large house battery bank which can be used to start the engines in an emergency. In this case, we recommend using OFF-ON switches, and a two bank Battery Combiner. See Figure 6.

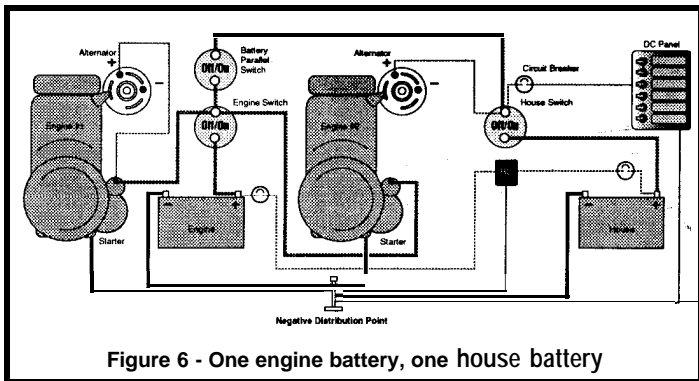

Figure 6 - One engine battery, one house battery

Method B-Boats with two house/one starting banks

Many cruisers like the idea of having two house banks in case one battery bank fails, or to allow one bank to rest every other day. Figure 7 shows one of several wiring methods using a three bank Battery Combiner. The use of two OFF-I-BOTH-2 switches allows you to use either house bank for house loads, and to use the house banks if your engine battery is dead. We would generally recommend that the house batteries be left paralleled together for minimal voltage drop.

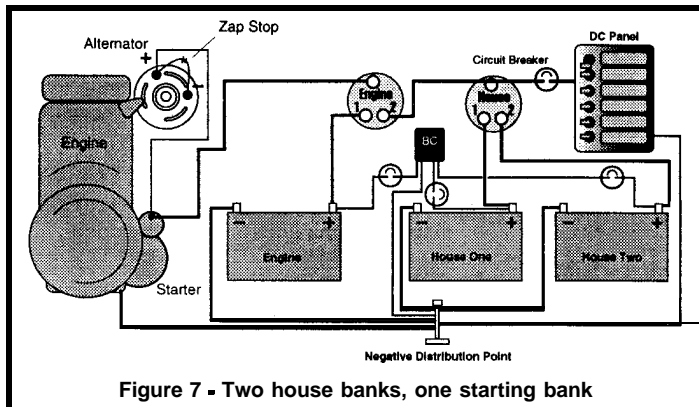

Figure 7 - Two house banks, one starting bank

GENERAL SAFETY TIPS

1. When installing the Battery Combiner, or when working on your electrical system, remove the positive battery cables from the battery terminals to eliminate the chance of a short circuit.
2. Follow ABYC guidelines for circuit protection, wire sizes, and other safety related issues.
3. Since the connections made in the battery circuits can conduct hundreds of amps, it is imperative that you have low resistance connections. This means having clean metal to metal connections, the right size ring terminals, properly crimped terminals, and secure mechanical fasteners.
4. If possible, use at least a 3' length of wire between each battery and the Battery Combiner. This will limit inrush current when you have severely discharged batteries connected to fully charged batteries. Using larger gauge wire will negate this benefit.

INSTALLATION INSTRUCTIONS: 70 AMP MODELS

Warning:

The Combiner is rated for 70 amps continuous and 200 amps momentarily. An internal thermal circuit breaker provides protection from overload; however, it should not be intentionally used to limit current in normal use.

Location:

Mount the Combiner in a dry place within a convenient distance to all battery banks. Refer to the six connection options, above, to determine the best place to connect the Battery Combiner to the electrical system. Use 8 AWG wire at least 3 feet long from each positive connection point to the large terminals on the top of the Battery Combiner. Connect a 16 AWG ground wire from the small terminal to ground to complete the wiring. If you desire an on/off switch to disable the Combiner, put the switch in the ground wire circuit. You should also have a high current fuse (100 A slow-blow) or circuit breaker in each wire leading to the Battery Combiner.

INSTALLATION INSTRUCTIONS: 130 AND 200 AMP MODELS

The 130 and 200 amp Battery Combiners operate exactly the same as the 70 amp versions. The difference is that these models use one or two contactors which are mounted externally. The gray circuit box can be mounted to any flat surface using the small mounting tabs, and the contactor can also be mounted using its (their) mounting feet.

The black and white wires connect to the two small terminals at the bottom of the contactor. It does not matter which wire connects to which terminal. The brown and red wires are sense wires for the voltage of the two battery banks, which connect with the battery connection wires at the top of the contactor. The ground wire on the gray case is not at the same potential as the black wire which runs to the contactor(s). Do not connect the black wire which goes to the contactor(s) to ground.

Use 3' (minimum) of 6 AWG wire to connect the contactor on the Battery Combiner to the positive connection point of the electrical system. Use 4 AWG wire for the 200 amp model. Do not use shorter lengths of wire; the tiny amount of resistance is helpful to reduce the maximum current.

Installation Instructions: 130 I200 Amp 3-Bank

To convert your 2-bank 130 and 200 amp Battery Combiners to combine three banks, you need to add a second contactor to the installation. Additional black and white wires run from the first contactor to the upgrade contactor, and the green wire is used to sense voltage on the third battery bank. The bus bar is used to connect two contactor terminals together. It is important to sense the two terminals without the bus bar, and have one wire sense the connected terminals with the bus bar. See Figure 8.

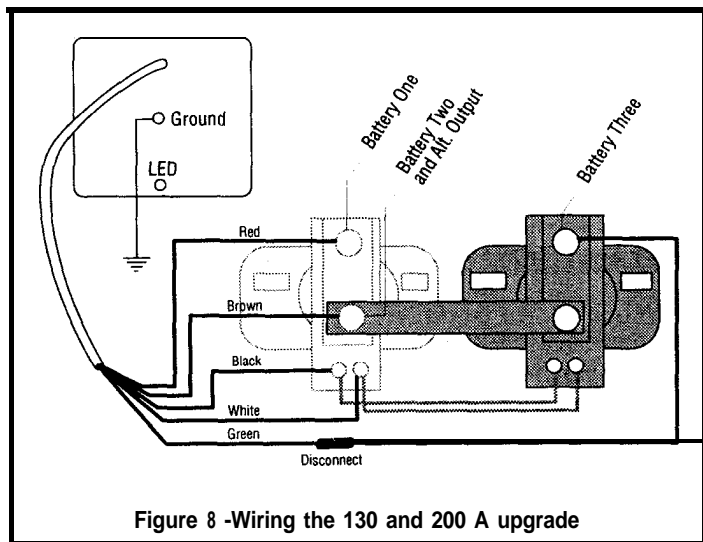

Figure 8 -Wiring the 130 and 200 A upgrade

ALTERNATOR OUTPUT WIRING:

There are two possibilities to consider when wiring the alternator output. Normally, the alternator output is connected directly to the starter motor, which in turn is connected to the common terminal of the battery switch. (Figure 9) This works OK when you use your battery switch to select which battery gets charged, but you run the risk of damaging your alternator's diodes by turning the battery switch OFF when the engine is running (with or without a Battery Combiner). This also causes the Battery Combiner to conduct all of the charging current which flows into the house bank, which is generally the discharged bank. A better solution, in our opinion, is to connect the alternator output to the **house battery bank** by connecting it to the load side of the house battery switch. When the house bank rises to 13.1 V DC, the Battery Combiner will close and allow the engine starting battery to charge in parallel. See Figure 10.

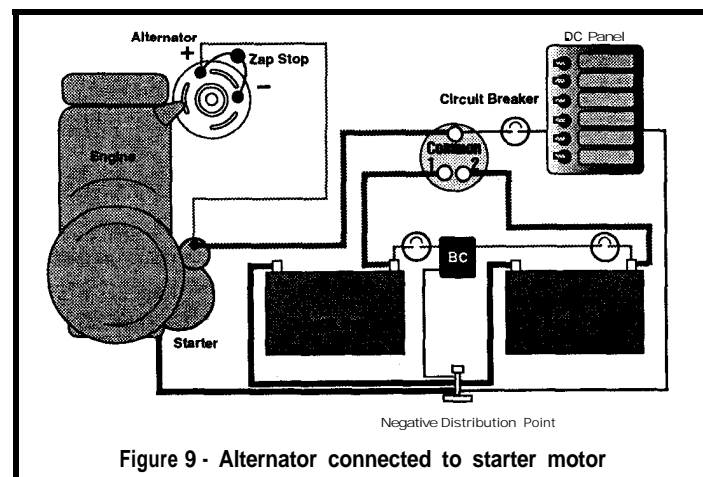

Figure 9 - Alternator connected to starter motor

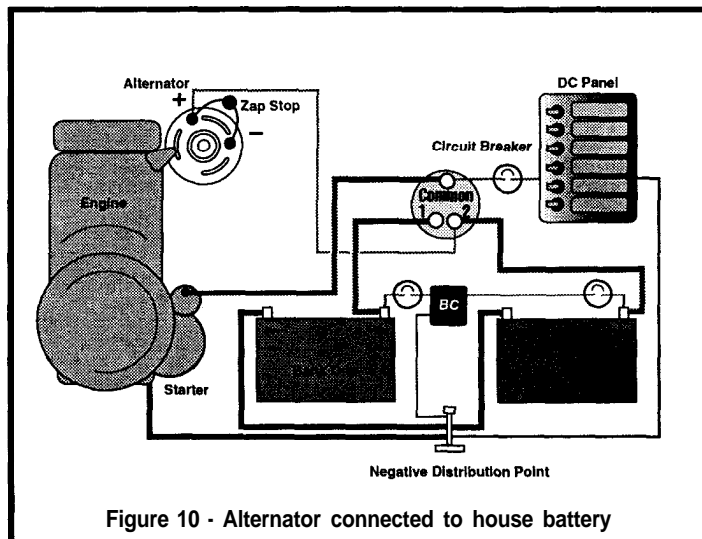

Figure 10 - Alternator connected to house battery

When wiring your alternator directly to the batteries in a three bank installation, we recommend that you connect the "alternator battery" to the central terminal on either the 70,130, or 200 amp contactors.

NOTE: If the alternator output becomes open-circuited in use, its diodes can be overloaded causing the alternator to fail. A *Zap-Stop*, or similar alternator protection diode, can reduce the chance of alternator damage, and is recommended for all installations.

NOTE: It is very important to prevent the alternator/regulator "sense" wire from becoming disconnected from the alternator output. While the sense wire should be connected as close as possible to the battery so that it senses accurate battery voltage, it may cause the alternator to produce **damaging voltages** if it becomes disconnected from the **alternator** output. Installation of a *Zap-Stop* will not protect against electrical system damage if this happens.

BATTERY CHARGE DEVICE WIRING:

A single output shore power charger can be directly connected to the load side of the house battery switch, or the common terminal of a single battery switch. Multi-bank chargers can be connected to each of the battery banks, or can have their outputs connected together to one battery bank. If you have dual alternators, connect each directly to its own bank, so when the Combiner closes the circuit, either engine will be charging both battery banks.

OPERATION AND TESTING:

The light will come on some time after charging has commenced. The time delay depends on how much current is being delivered to the house bank and its initial state of charge - a high charge turns it on fairly quickly, while a trickle charge may take many minutes. When that bank reaches 13.1 volts, the other bank(s) will be added to the alternator load. If one bank is very low, the Combiner may turn off and on a number of times as it brings it up to voltage. After charging has ceased, the light may remain on if there is no load, but the "float" voltage of the batteries is above 12.8 volts. Before any significant power is drawn from the batteries, however, the Combiner will turn off.

WARRANTY:

1 year. Made in the U.S.A. by West Marine.

1996 West Marine.
Corporate address: 500 Westridge Dr., Watsonville, CA 95076